

構成内容 / Components				
No.	名称 / Part name	数量 / Pcs	材質 / Material	色・表面処理 / Color・Finish
1	上カバー Top cover	1	ABS樹脂 UL94HB ABS UL94HB	ライトグレー, ブラック Light gray, Black
2	下カバー Bottom cover	1	ABS樹脂 UL94HB ABS UL94HB	ライトグレー, ブラック Light gray, Black
3	取付ビス(M3 x 16 丸皿タッピング) Screw(M3 - 16 Raised countersunk head self tapping)	4	鉄 Steel	三価クロメート, 三価黒クロメート Trivalent chromate, Black trivalent chromate

■テクニカルデータ / Technical Data■

使用温度範囲 / Operating temperature : -10°C ~ +60°C

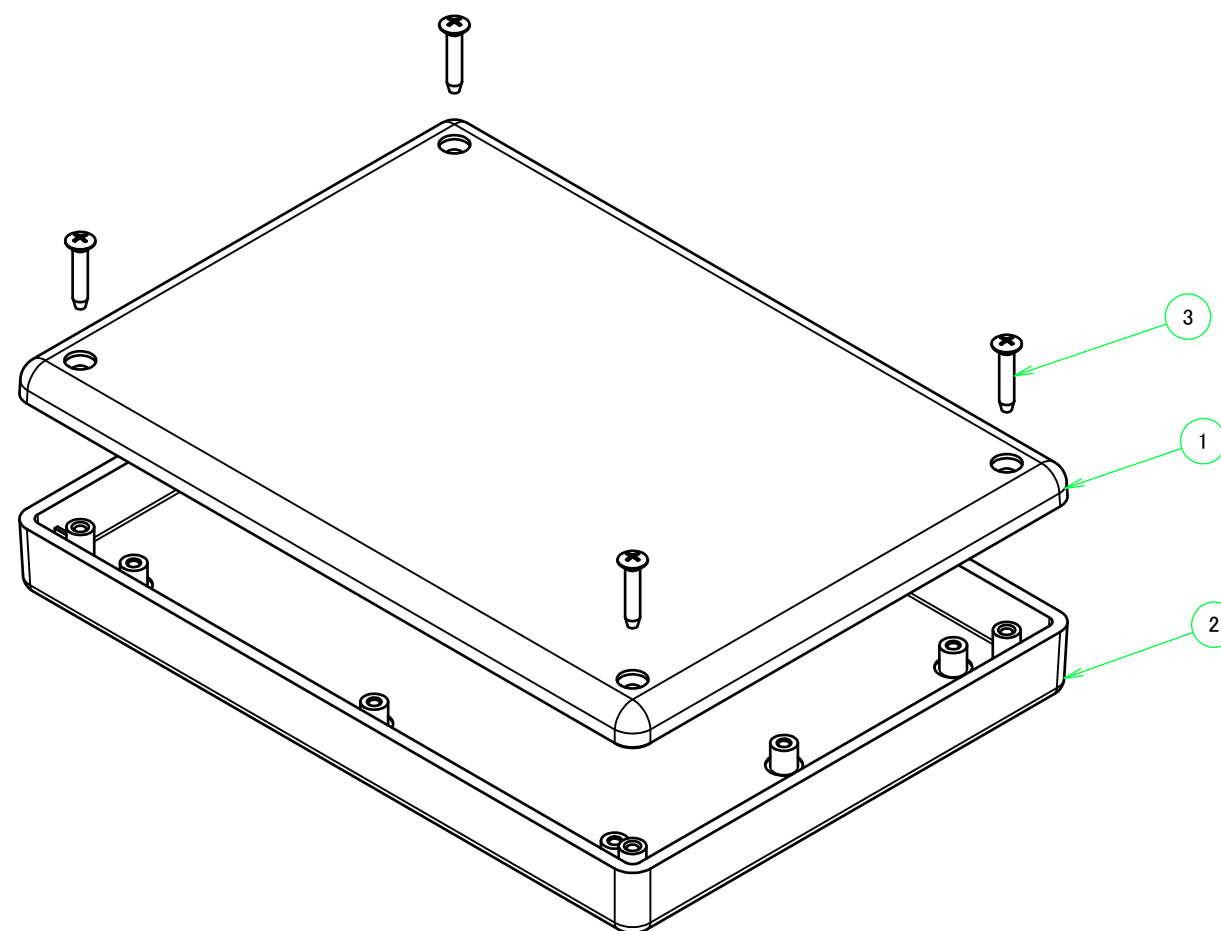

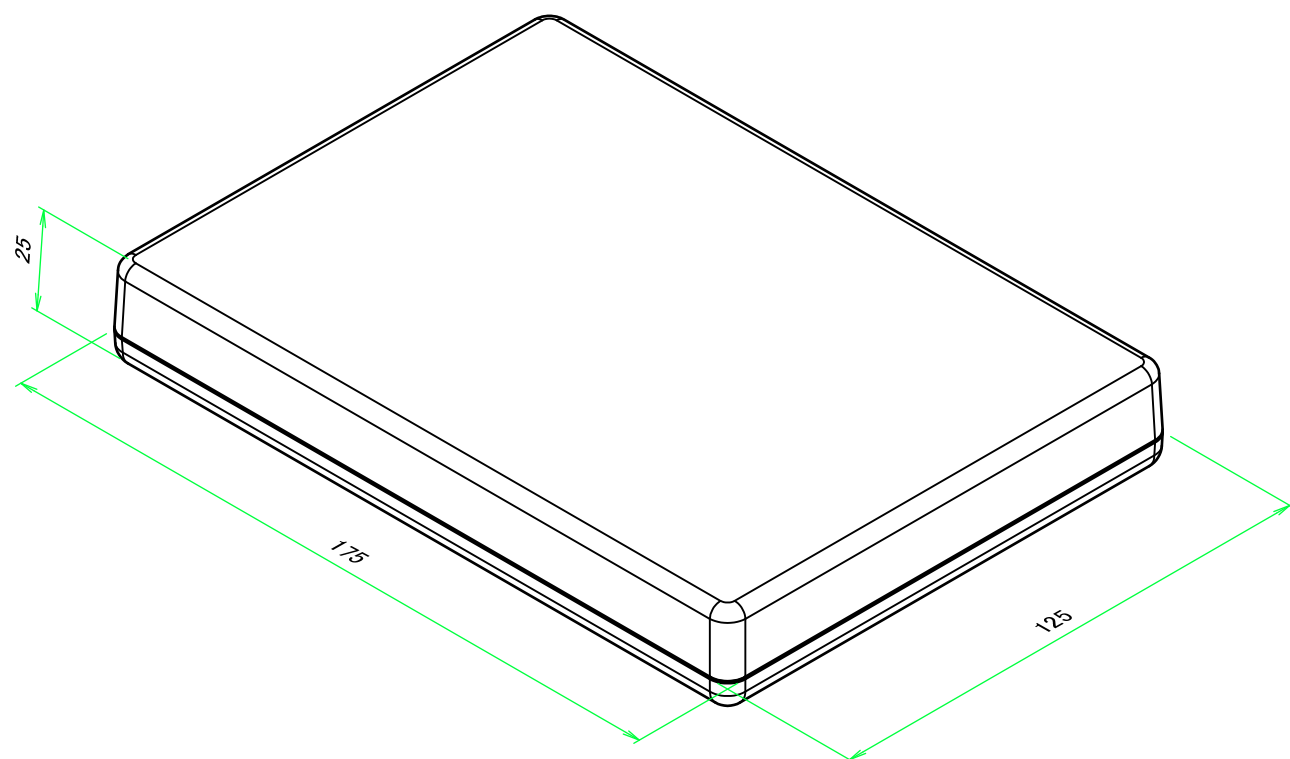
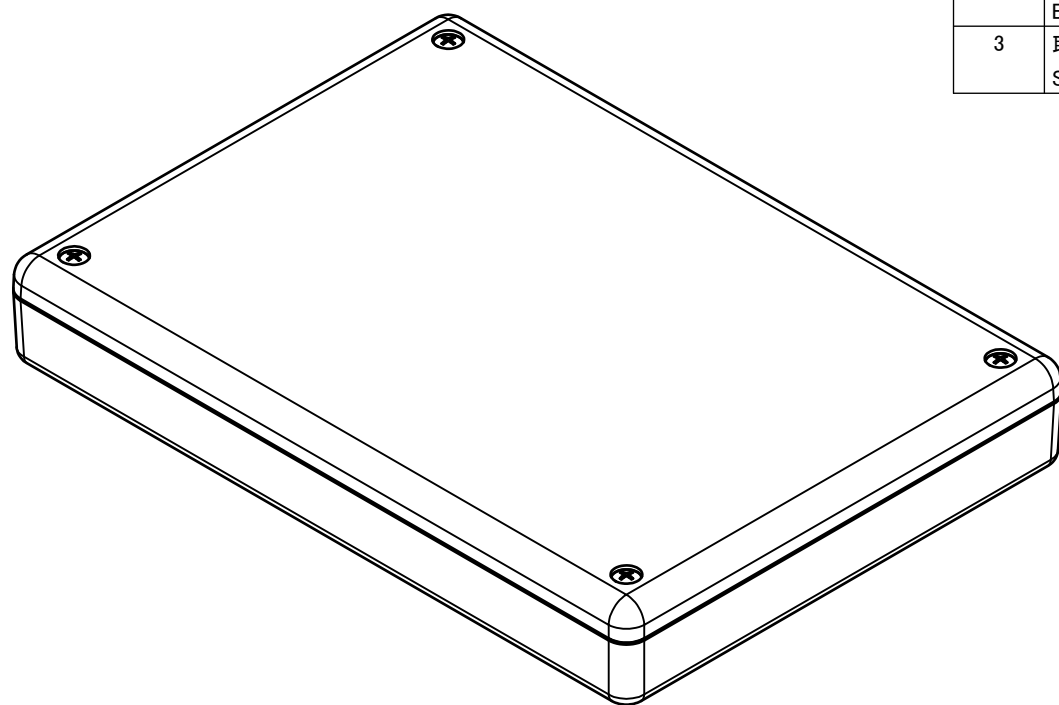

色仕様(型番末尾口) / Color Type(End of product number)	
記号 / Code	色 / Color
G	ライトグレー / Light gray
B	ブラック / Black

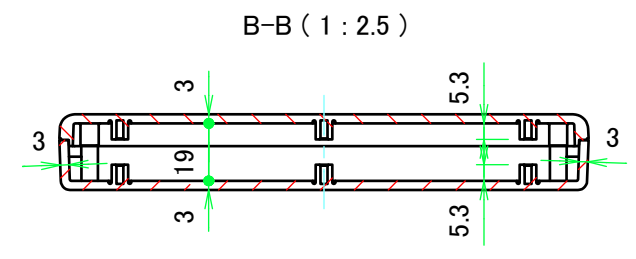
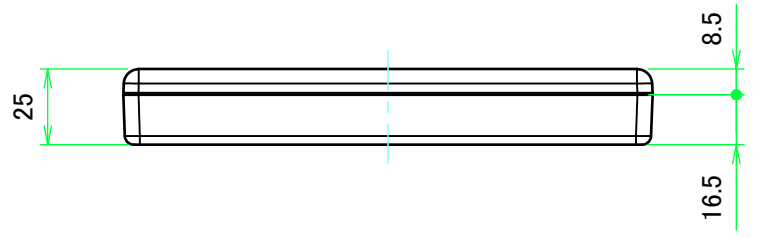
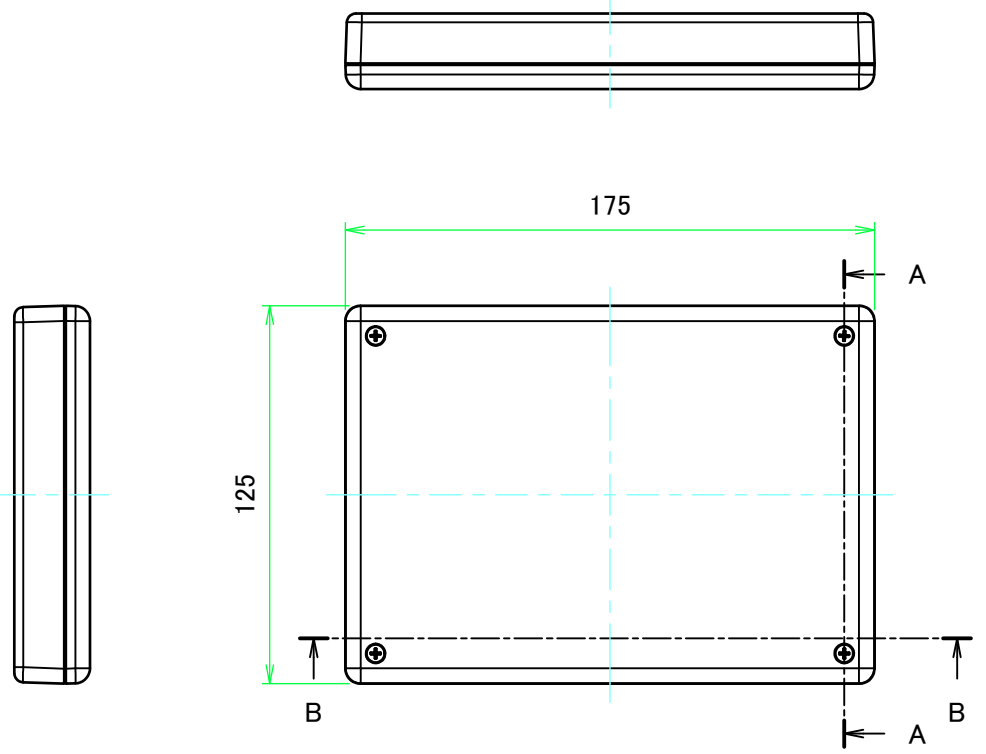
株式会社タカチ電機工業 TAKACHI ELECTRONICS ENCLOSURE CO., LTD.	承認/Approved	検図/Checked	製図/Created	品名/Title	尺度/Scale 1:1.5
				プラスチックケース PLASTIC ENCLOSURE	
				型番/Product number	1 / 4
				TW13-3-18□	
				作成日/Date	2017/07/26

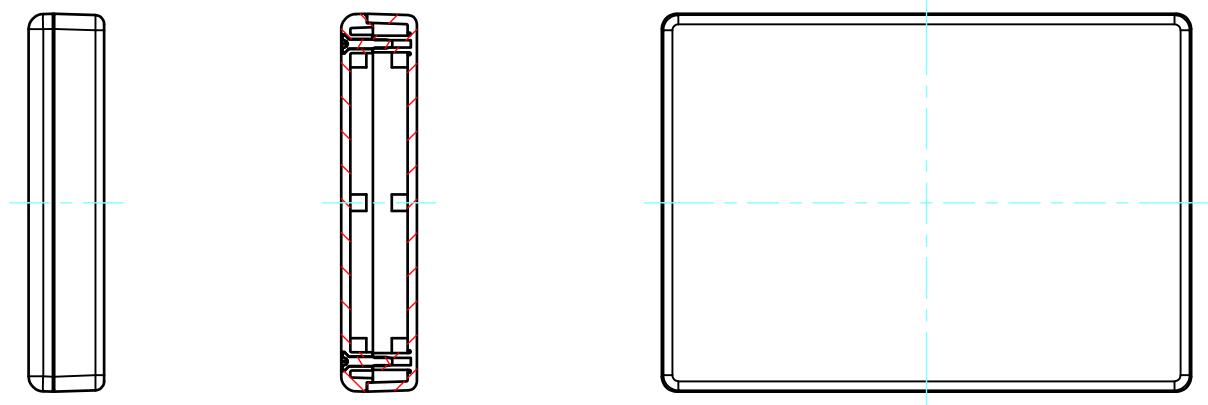

A-A (1:2.5)

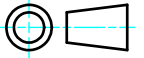

 <b>株式会社タカチ電機工業</b> <small>TAKACHI ELECTRONICS ENCLOSURE CO., LTD.</small>		品名/Title <b>プラスチックケース</b> PLASTIC ENCLOSURE	 尺度/Scale 1:2.5
承認/Approved	検図/Checked	製図/Created	
	野村	横田	作成日/Date 2017/07/26
			2 / 4

上カバー / Top cover

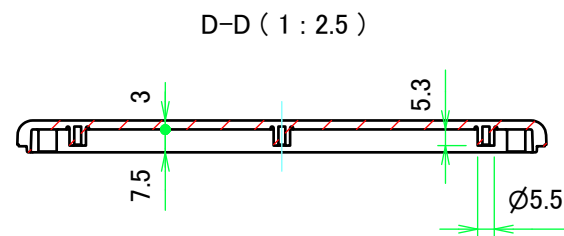
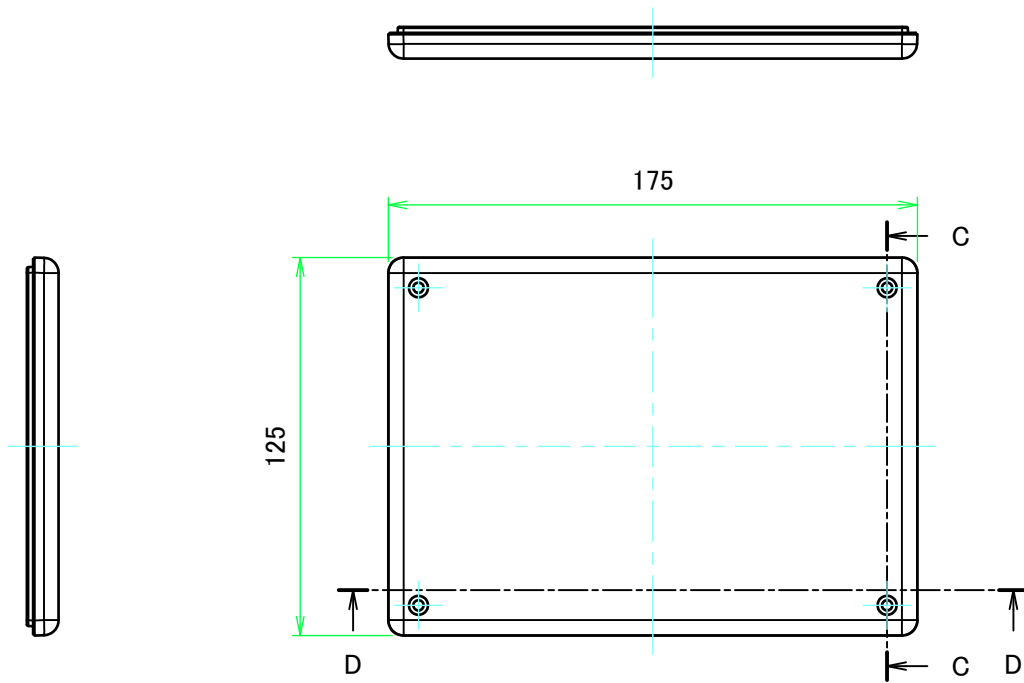

C-C (1:2.5)

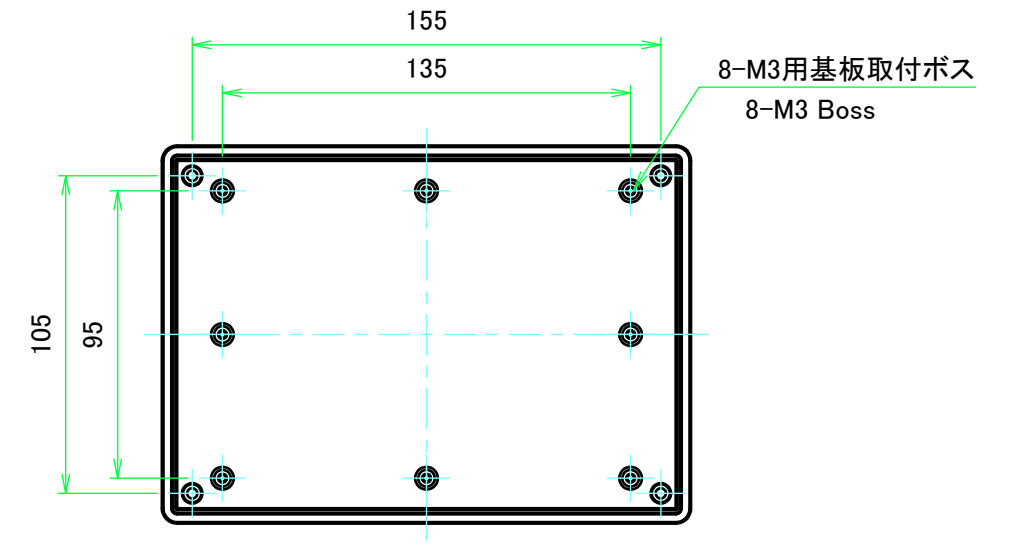
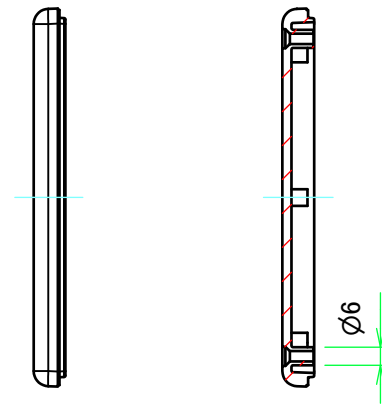

推奨基板形状 \* 販売していません  
Recommended PCB dimension \* NOT SUPPLIED

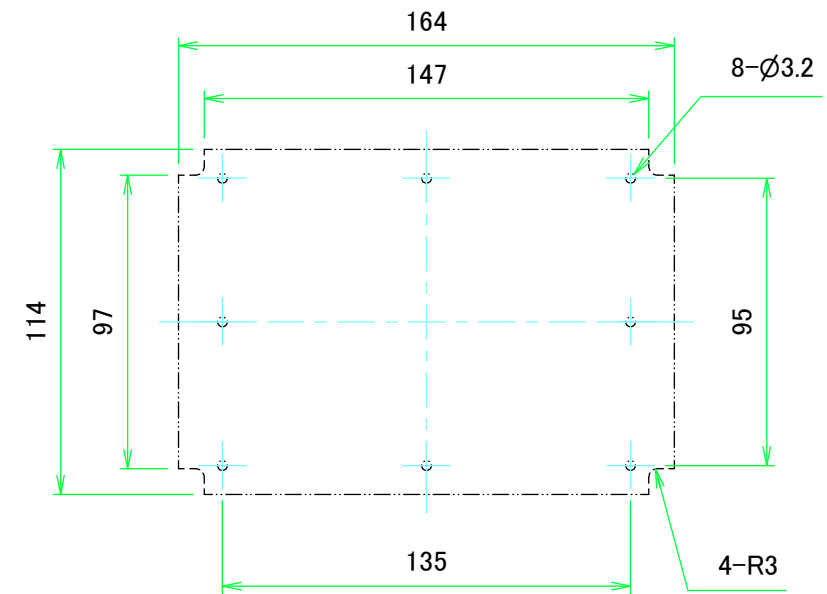

株式会社タカチ電機工業 TAKACHI ELECTRONICS ENCLOSURE CO., LTD.			品名/Title プラスチックケース PLASTIC ENCLOSURE	尺度/Scale 1:2.5
承認/Approved	検図/Checked	製図/Created	型番/Product number TW13-3-18□	
	野村	横田	作成日/Date 2017/07/26	3 / 4

下カバー / Bottom Cover

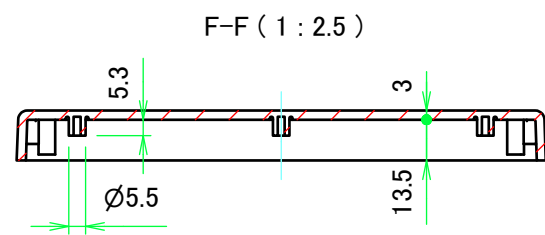
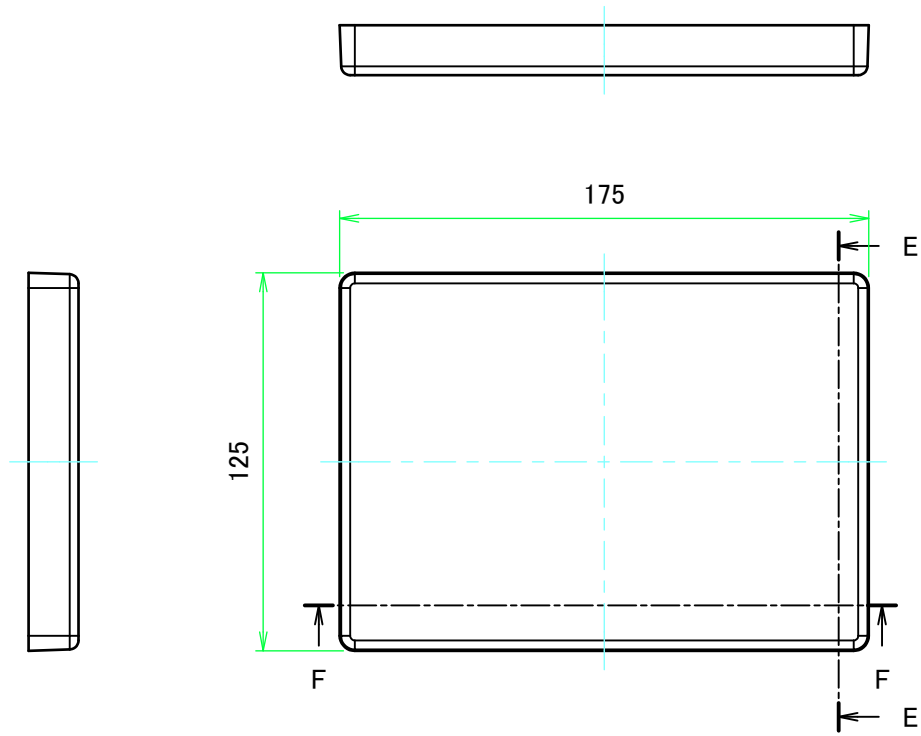

E-E (1:2.5)

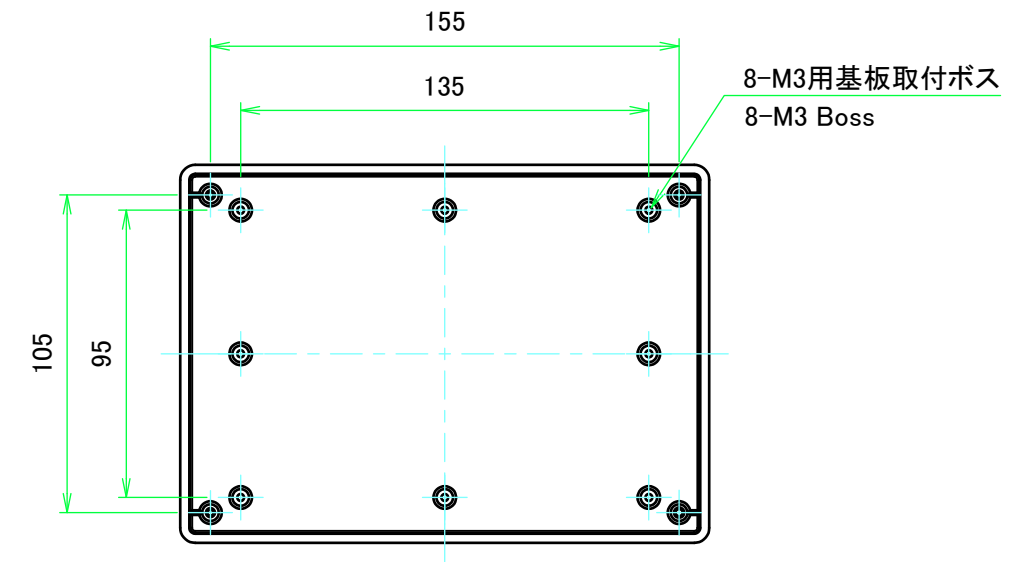
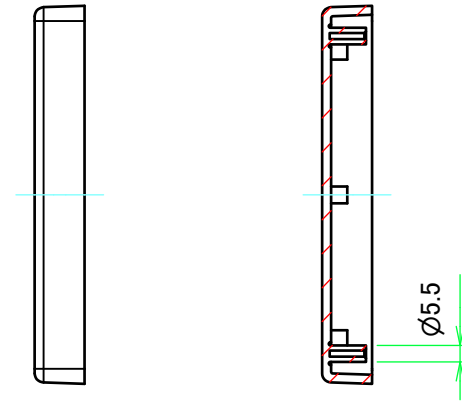

推奨基板形状 \* 販売していません  
Recommended PCB dimension \* NOT SUPPLIED

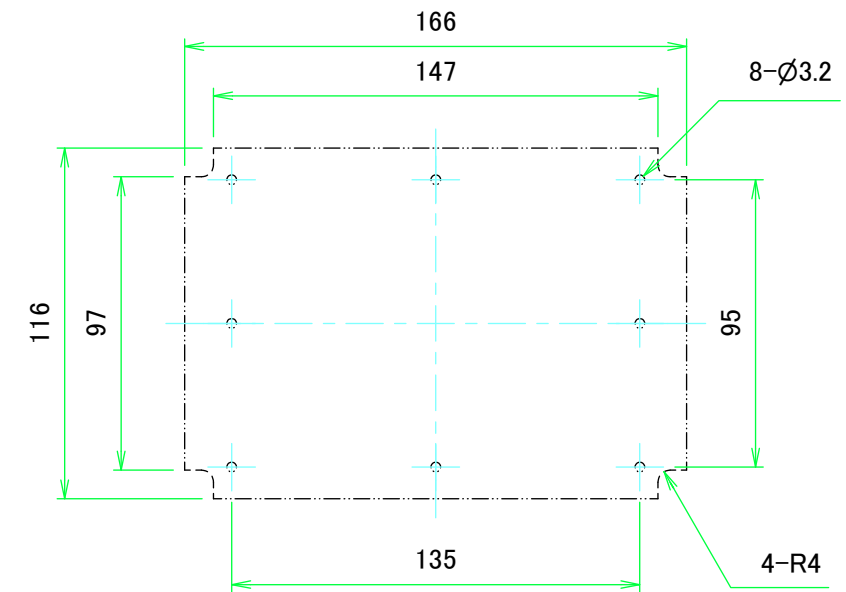

株式会社タカチ電機工業 TAKACHI ELECTRONICS ENCLOSURE CO., LTD.		品名/Title プラスチックケース PLASTIC ENCLOSURE	尺度/Scale 1:2.5
承認/Approved	検図/Checked	製図/Created	型番/Product number TW13-3-18□
	野村	横田	作成日/Date 2017/07/26
			4 / 4