

■テクニカルデータ/Technical Data■

使用温度範囲 / Operating temperature	-40°C~+105°C
※熱抵抗値 / Thermal resistant rate	9.18°C/W

※熱抵抗値算出の条件 / Thermal resistance test condition

- ・自然空冷 / Ambient air cooling
- ・フィンが地面に垂直で温度上昇60°Cの時 / Heat-sink fins are set perpendicular to the ground with temperature at 60°C
- ・押出しがアルマイト品 / Anodized extruded aluminium
- ・全面素子 / Heat source is applied on the opposite side (inner side) of the fins

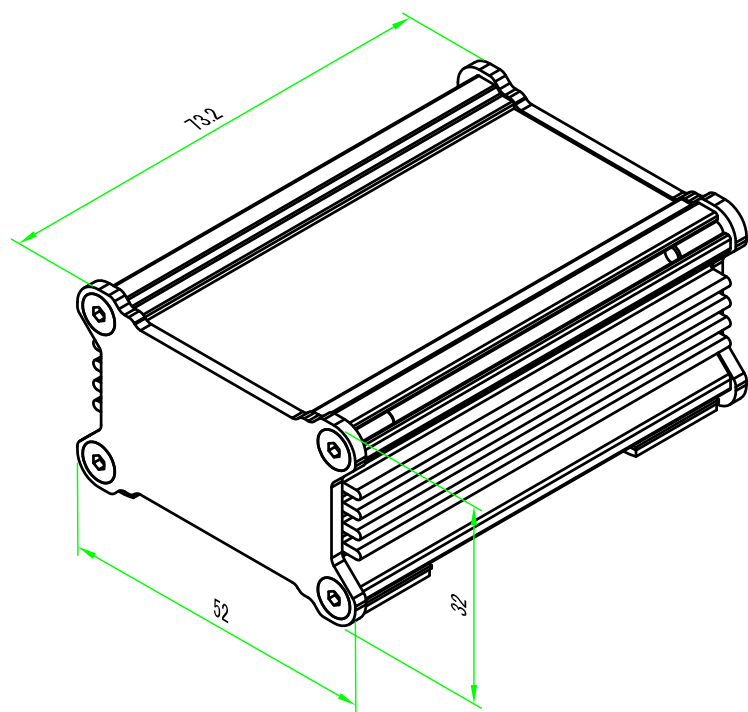

構成内容 / Components

No.	名称 / Part name	数量 / Pcs	材質 / Material	色・表面処理 / Color・Finish
1	ボディフレーム / Body frame	1	アルミ押出材 / Extruded aluminium A6063S-T5	シルバーアルマイト & クリア塗装 / Silver anodized & clear coated
2	パネル / End panel	2	アルミ板 / Aluminium A1050P	表面シルバーアルマイト:裏面未処理 / Silver anodized(outside):Unfinished(inside)
3	取付ビス(六角穴付皿M3×10) / Hex socket screw	8	ステンレス / Stainless steel	無処理 / Unfinished
4	ゴム足 / Rubber feet	4	ポリウレタン / Polyurethane	ブラック / Black

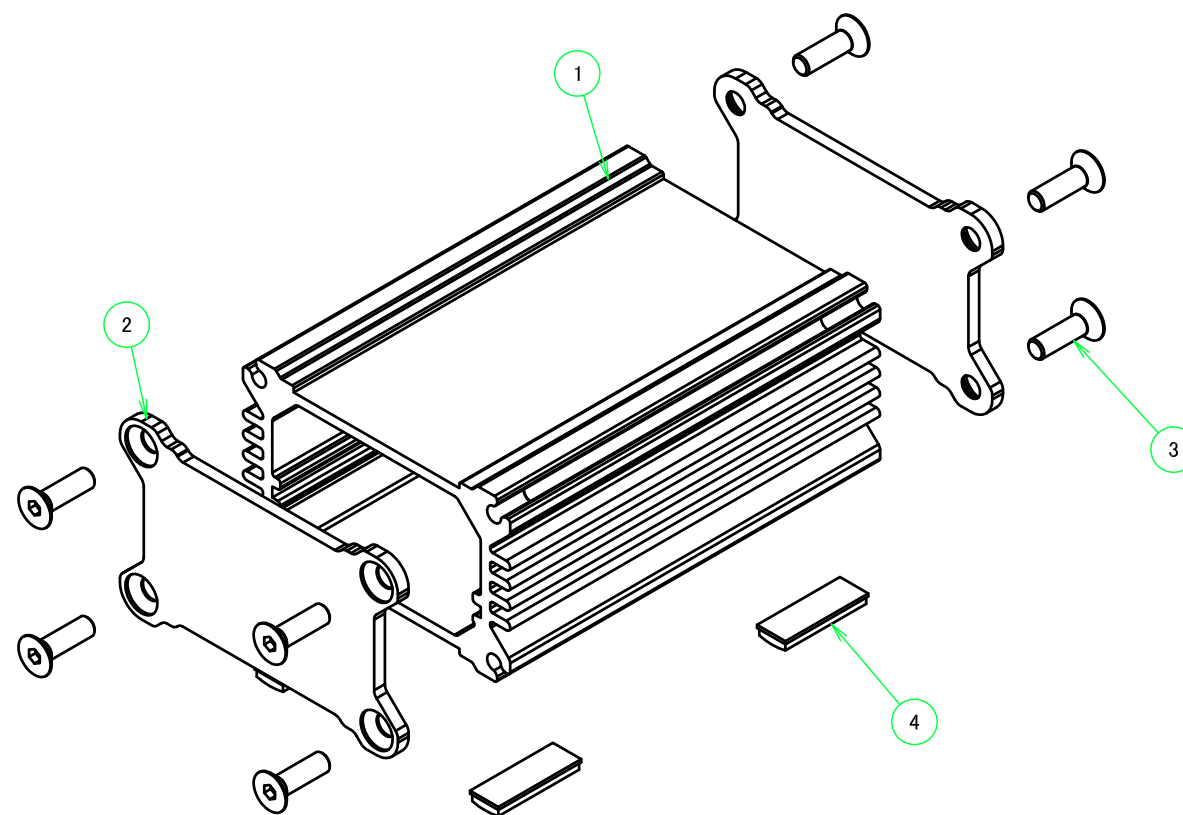

株式会社タカチ電機工業 TAKACHI ELECTRONICS ENCLOSURE CO., LTD.			品名/Title アルミ放熱ケース HEAT-SINK ALUMINIUM ENCLOSURE	尺度/Scale 1 / 1
承認/Approved	検図/Checked	製図/Created	型番/Product number AWA5-3-7SS	
中根	王	岡本	作成日/Date 2020/11/11	1 / 4

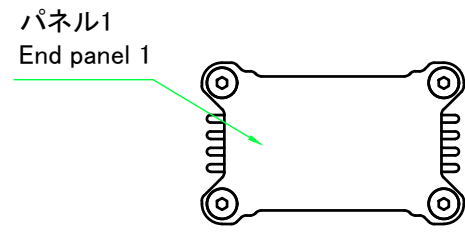

B-B (1 : 1.5)

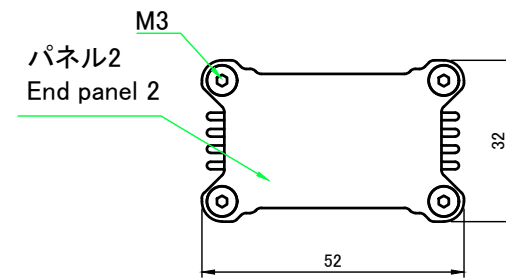
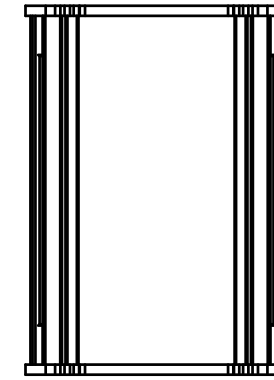
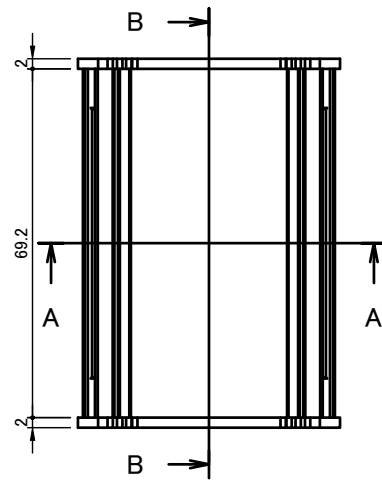
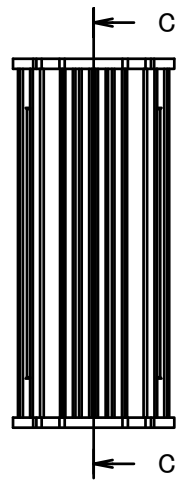
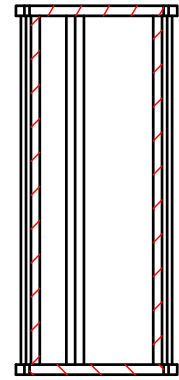

C-C (1 : 1.5)

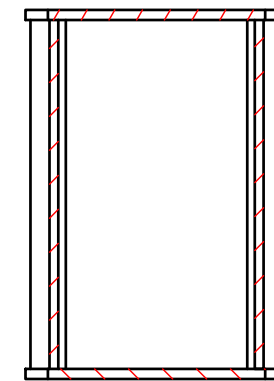

A-A (1 : 1.5)

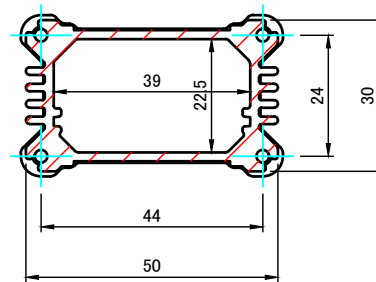

株式会社タカチ電機工業 TAKACHI ELECTRONICS ENCLOSURE CO., LTD.			品名/Title アルミ放熱ケース HEAT-SINK ALUMINIUM ENCLOSURE	尺度/Scale 1 / 1.5
承認/Approved	検図/Checked	製図/Created	型番/Product number AWA5-3-7SS	
中根	王	岡本	作成日/Date 2019/02/26	2 / 4

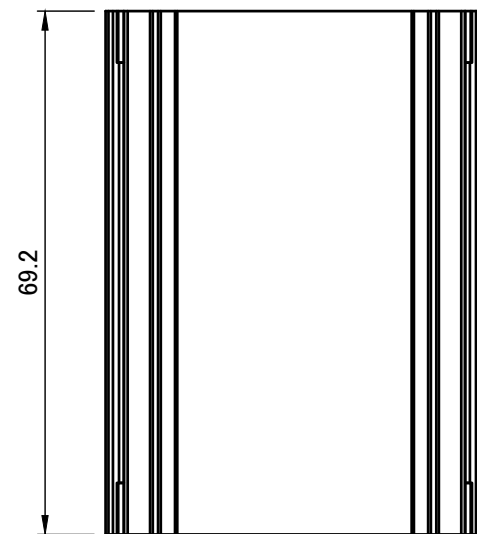
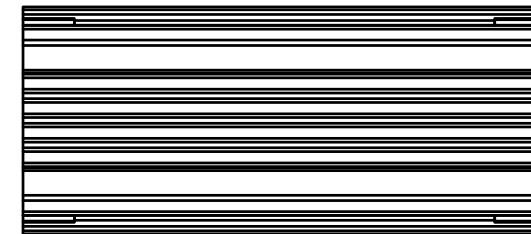
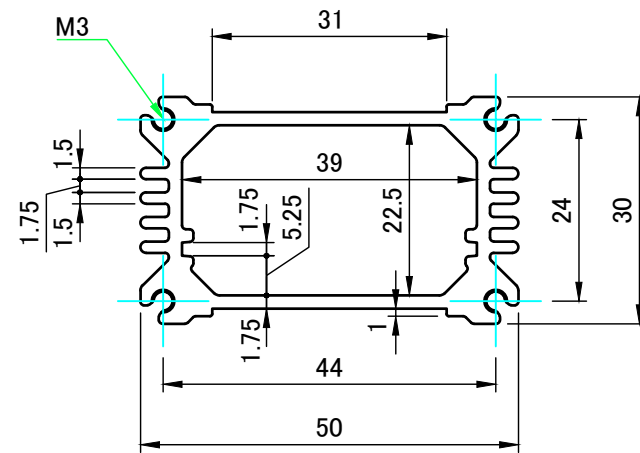
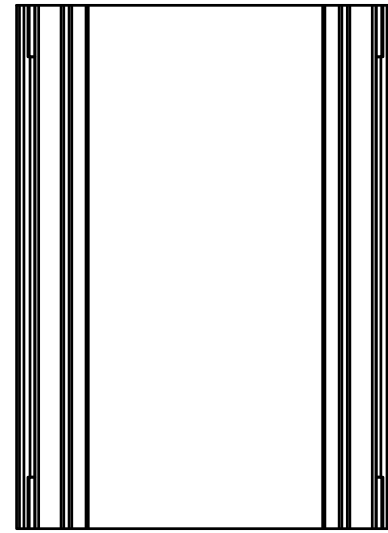
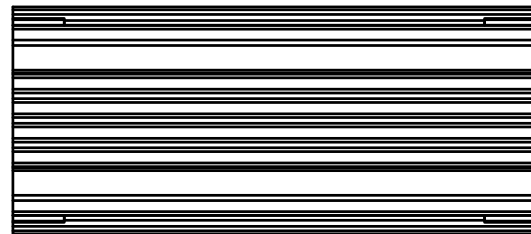

		株式会社タカチ電機工業 TAKACHI ELECTRONICS ENCLOSURE CO., LTD.		品名/Title ボディフレーム Body frame	
承認/Approved 中根	検図/Checked 王	製図/Created 岡本	型番/Product number W50-H30-H69.2	尺度/Scale 1:1	
				作成日/Date 2019/02/26	3 / 4

パネル1
End panel 1

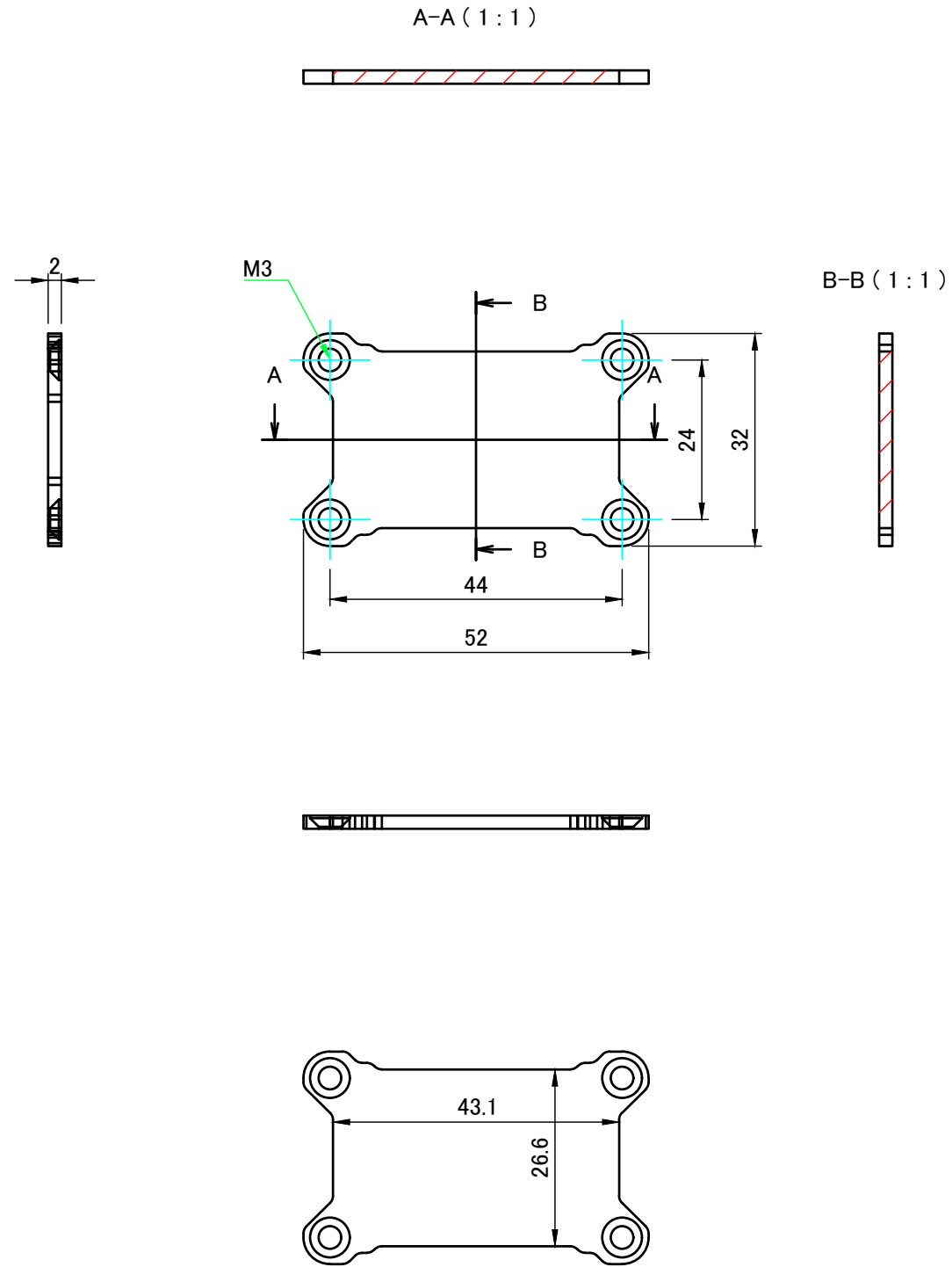

パネル2
End panel 2

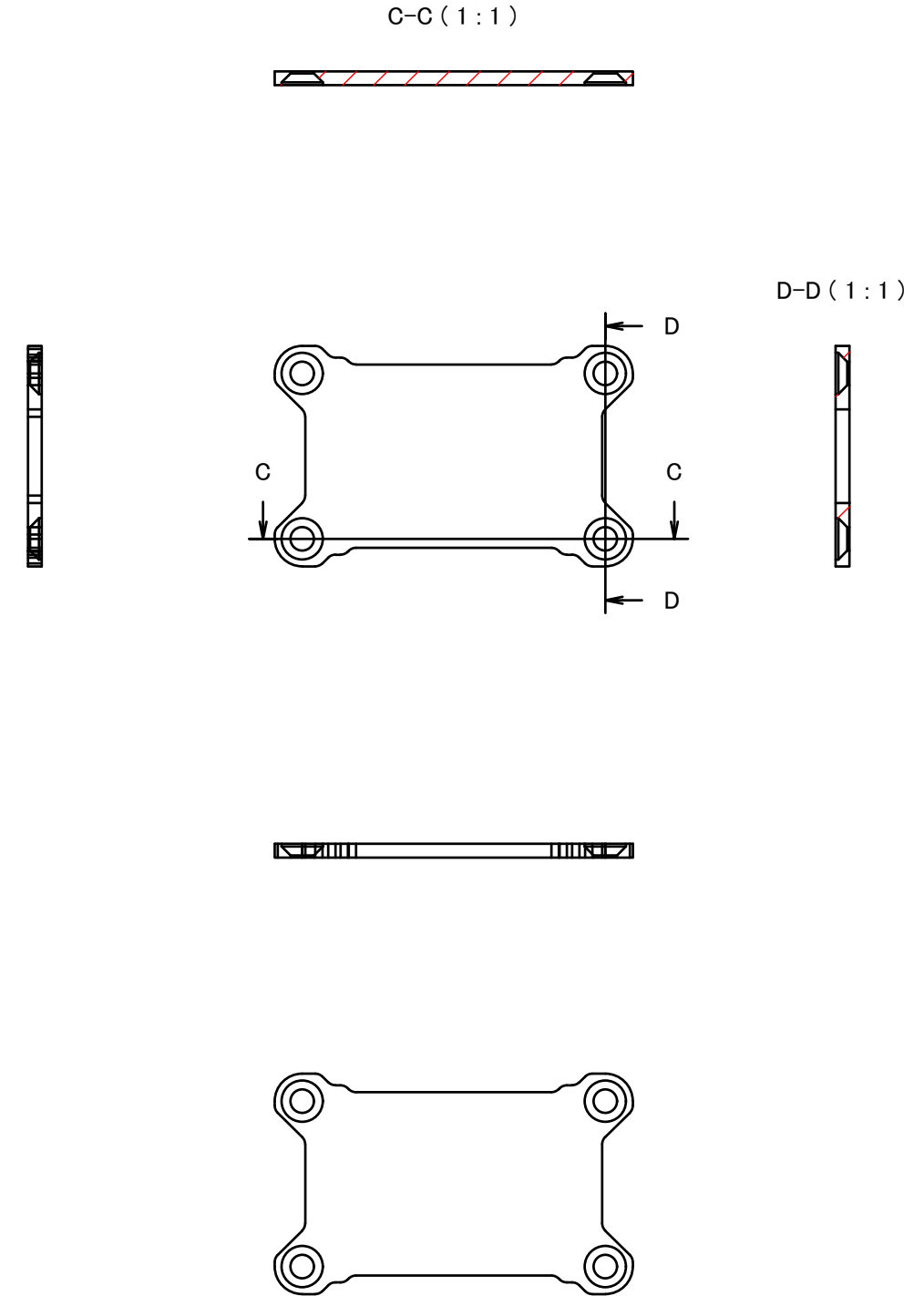

株式会社タカチ電機工業 TAKACHI ELECTRONICS ENCLOSURE CO., LTD.			品名/Title パネル End panel	
承認/Approved	検図/Checked	製図/Created	型番/Product number W50-H30	尺度/Scale 1 / 1
中根	王	岡本	作成日/Date 2019/02/26	4 / 4